



FITTING INSTRUCTIONS FOR LP0343 LICENCE PLATE BRACKET



**This kit contains the items pictured and labelled over page.
Some parts may be shown for clarity of instructions only.
Do not proceed until you are sure all parts are present.
Please read all instructions before proceeding.**

**IF IN ANY DOUBT WHEN FITTING OUR PRODUCTS, CONSULT ONE OF OUR DEALERS
OR HAVE FITTED BY A QUALIFIED TECHNICIAN.**

Please note that the way the kit is packed does not necessarily represent the way of mounting to the bike.

In the event of rubber washers being used to hold components onto bolts, these rubber washers can be thrown away.

DIGITAL COPIES OF THESE INSTRUCTIONS ARE AVAILABLE FROM

WWW.RG-RACING.COM

R&G

Unit 1, Shelley's Lane, East Worldham, Alton, Hampshire, GU34 3AQ
Tel: +44 (0)1420 89007 Fax: +44 (0)1420 87301 www.rg-racing.com Email: info@rg-racing.com



<u>TOOLS REQUIRED</u>	<u>GENERAL TORQUE SETTINGS</u>
<ul style="list-style-type: none"> • Set of metric Hex keys to include 3mm, 4mm and 5mm. <ul style="list-style-type: none"> • T30 Torx head tool • Set of metric sockets and wrench. To include 6, 8 & 10mm. <ul style="list-style-type: none"> • 8mm & 10mm spanners. • Phillips screwdriver. 	M4 BOLT = 8Nm M5 BOLT = 12Nm M6 BOLT = 15Nm M8 BOLT = 20Nm M10 BOLT = 40Nm M12 BOLT = 40Nm

LEGEND

ITEM No.	DESCRIPTION	QTY
ITEM 1	TB0343 PART 1 LICENCE PLATE BRACKET	1
ITEM 2	TB0343 PART 2 LICENCE PLATE SUPPORT	1
ITEM 3	TB0299 PART 2 LICENCE PLATE MOUNT	1
ITEM 4	S0722 TAIL BRACKET MOUNTING SPACER	2
ITEM 5	S0294 SPACER	1
ITEM 6	M6 x 1.00 x 20mm BUTTON HEAD BOLT	2
ITEM 7	M6 x 1.00 x 25mm BUTTON HEAD BOLT	1
ITEM 8	M5 x 0.8 x 15mm COUNTERSUNK BOLT	8
ITEM 9	M6 x 12mm OD WASHER	3
ITEM 10	M6 x 19mm OD WASHER	2
ITEM 11	M5 x 10mm OD WASHER	8
ITEM 12	M6 NYLOC NUT	2
ITEM 13	M5 NYLOC NUT	8
ITEM 14	RB0002 RUBBER BUNG	1
ITEM 15	LA0002 NUMBER PLATE LIGHT	1
ITEM 16	666-896 150mm HEAT SHRINK	1
ITEM 17	CT100BK 2.5 x 100mm CABLE TIE	8
ITEM 18	CLIP 1 SELF ADHESIVE CABLE CLIP	4
ITEM 19	REFL 3 REFLECTOR	1
ITEM 20	CON0014 LICENCE PLATE ILLUMINATOR CONNECTOR	1

R&G

Unit 1, Shelley's Lane, East Worldham, Alton, Hampshire, GU34 3AQ

Tel: +44 (0)1420 89007 Fax: +44 (0)1420 87301 www.rg-racing.com Email: info@rg-racing.com



ASSEMBLY DIAGRAM 1

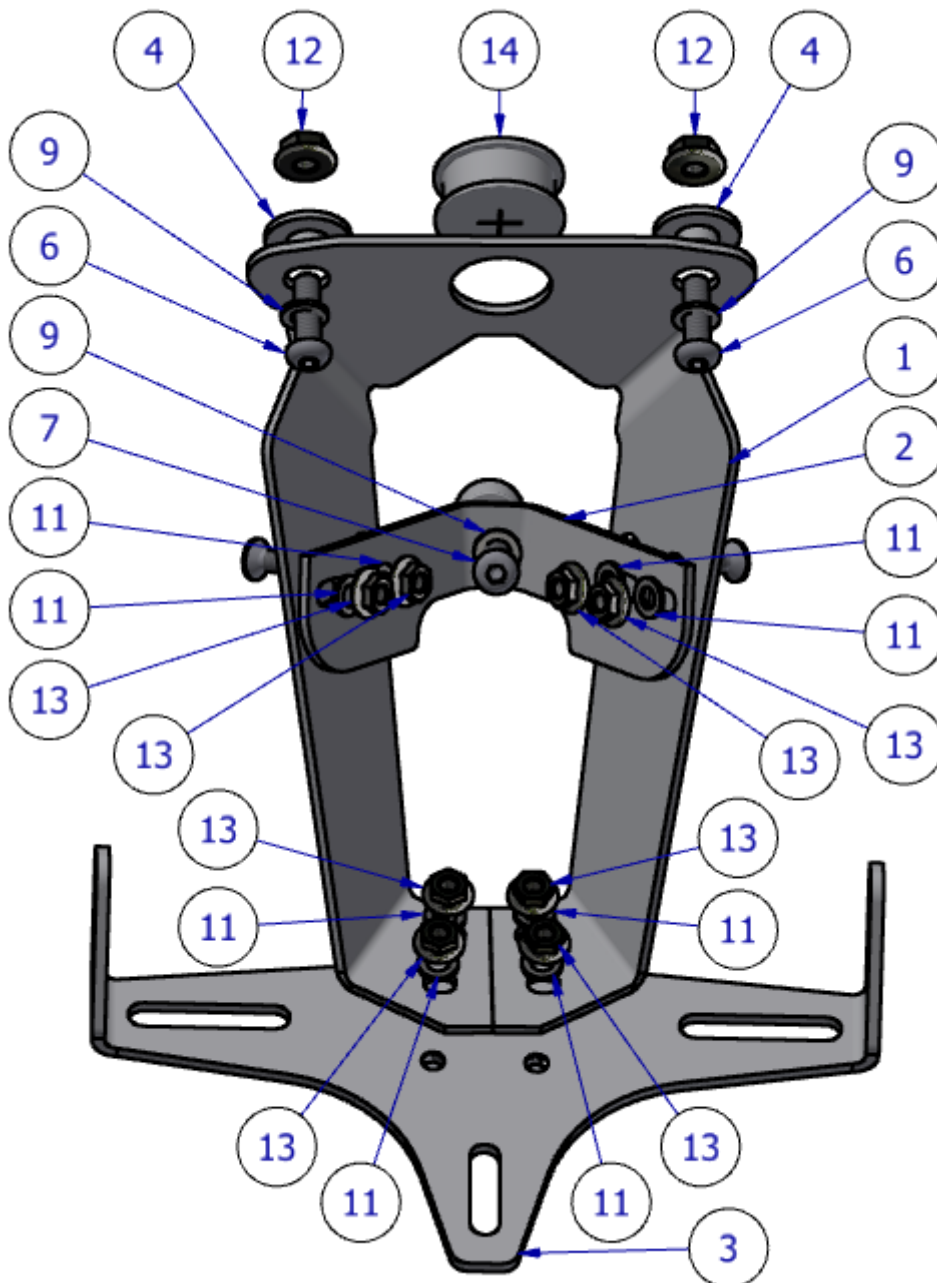

R&G

Unit 1, Shelley's Lane, East Worldham, Alton, Hampshire, GU34 3AQ

Tel: +44 (0)1420 89007 Fax: +44 (0)1420 87301 www.rg-racing.com Email: info@rg-racing.com



ASSEMBLY DIAGRAM 2

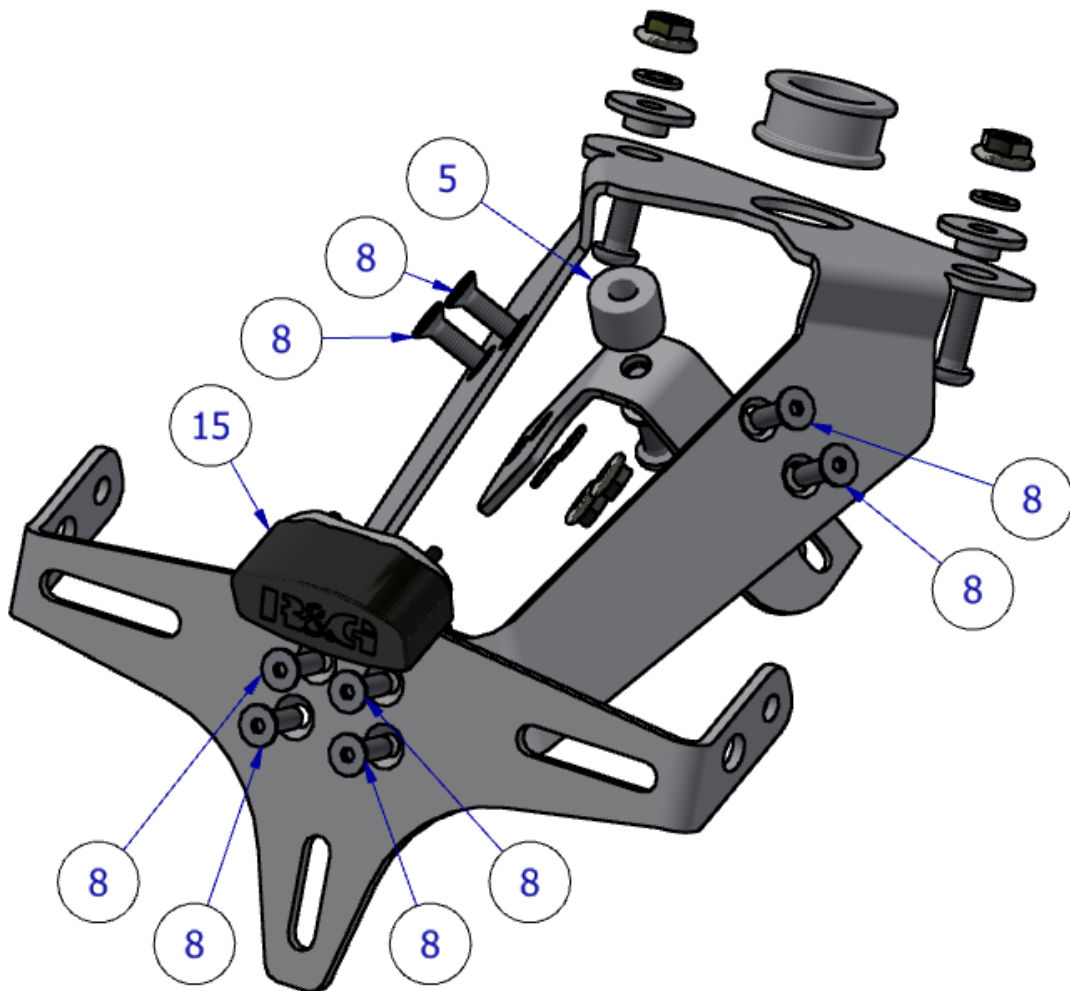

R&G

Unit 1, Shelley's Lane, East Worldham, Alton, Hampshire, GU34 3AQ

Tel: +44 (0)1420 89007 Fax: +44 (0)1420 87301 www.rg-racing.com Email: info@rg-racing.com



DIAGRAM 3

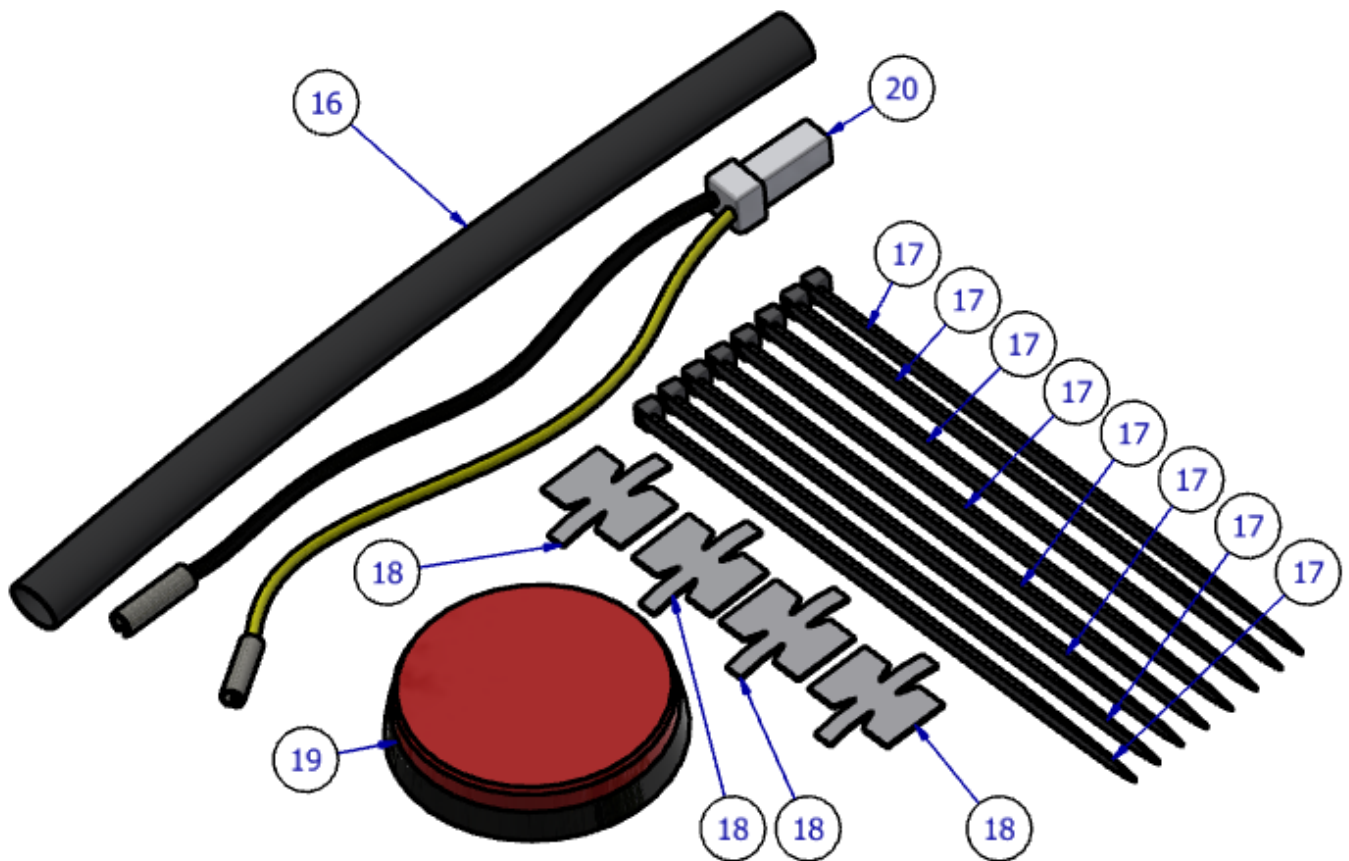



FITTING PICTURES



PICTURE 1



PICTURE 2



PICTURE 3



FITTING INSTRUCTIONS

Before fitting the R&G tail tidy you will need to remove some OEM parts. Below is a suggested list of parts to be removed.

- Rear seat
- Rear side panels
- Under rear seat cover plate
- OEM number plate bracket
- Seat lock mechanism
- OEM indicators
- Unplug indicator and number plate light wires

Tail Tidy Assembly

Before assembling this product, ensure all the components within the box are correct by comparing the **legend** and **diagrams**.

1. To start assembling the tail tidy, connect **(ITEM 1)** and **(ITEM 2)** together using x4 **(ITEM 8)** **(ITEM 11)** **(ITEM 13)** as shown in **DIAGRAM 1-2**. **DO NOT FULLY TIGHTEN AT THIS STAGE**.
2. Connect **(ITEM 3)** to the now constructed assembly **(ITEM 1/2)** using x4 **(ITEM 8)** **(ITEM 11)** **(ITEM 13)** as shown in **DIAGRAM 1-2**.
3. Once **(ITEM 3)** is connect, you can attach **(ITEM 15)** into the mounting holes on **(ITEM 3)** as shown in **DIAGRAM 2**. **MAKE SURE WIRES ARE PLACED THROUGH (ITEM 3)**. Once tightened, slide the **HEAT SHRINK (ITEM 16)** over the wires of **(ITEM 15)**.
4. As shown in **DIAGRAM 1** push **(ITEM 14)** into the hole of **(ITEM 1)**.
5. To help cable tidy the wires, you will need to use the SELF-ADHESIVE CABLE CLIP **(ITEM 18)** to pin the wires to the inside of **(ITEM 1)** on either side.
6. Push the cables through the hole in **(ITEM 14)**.
7. To install the **TAIL BRACKET MOUNTING SPACERS (ITEM 4)**, you will need to directly replace the OEM SPACERS as shown in **PICTURE 1**.
8. Now the Tail Tidy is assembled, it is time to attach it to the motorbike. To do so place the assembly in the same mounting location as the OEM number plate bracket using x2 **(ITEM 6)** **(ITEM 9)** **(ITEM 12)**.

R&G

Unit 1, Shelley's Lane, East Worldham, Alton, Hampshire, GU34 3AQ

Tel: +44 (0)1420 89007 Fax: +44 (0)1420 87301 www.rg-racing.com Email: info@rg-racing.com

**MAKE SURE TO DO-**

Make sure the washer **(ITEM 9)** is placed onto the bolt **(ITEM 6)** before being mounted. Also slot the wires through the small hole in the rear undertray as shown in **PICTURE 2**.

Once the tail tidy is mounted to the bike, ensure it is tight and secure.

9. After mounting the tail tidy, the centre bolt **(ITEM 7)** with washer **(ITEM 9)** will need to be bolted through the mounting hole in the LICENCE PLATE SUPPORT **(ITEM 2)** as shown in **DIAGRAM 1-2**.

Make sure that the SPACER **(ITEM 5)** is placed in between the bike mounting location and **(ITEM 2)**.

10. Plug in the Number plate light **(ITEM 15)** wires into the Licence plate illuminator connector **(ITEM 20)** as shown in PICTURE 3. Once connected, plug **(ITEM 20)** into the motorbikes OEM number plate light connector.
11. Now fully tighten **(ITEM 1)** and **(ITEM 2)**.
12. Ensure that all the nuts and bolts have been tighten properly using the **GENERAL TORQUE SETTINGS** table on **PAGE 2**.
13. Turn the motorbike on to test the Number Plate Light **(ITEM 15)** is working.
14. To install the OEM indicators, remove these from the OEM tail unit by removing the securing nut from each indicator and thread the wire through the bracket to remove.

Ensuring to fix the indicators to the correct side, thread the connector and wire through the indicator mount on the licence plate bracket and the wire hole on **(ITEM 1)**. Then tighten the indicators securely with the with the OEM indicator nut.

15. Final step, re-install all OEM parts except from the OEM Number Plate Bracket.

IMPORTANT: IF FITTING A FULL-SIZE LICENCE PLATE AND PLACING IT LOW DOWN ON THE LICENCE PLATE MOUNT, THERE IS A POTENTIAL CHANCE THE LICENCE PLATE COULD HIT THE BACK WHEEL UNDER HEAVY LOAD AND OVER LARGE BUMPS IN THE ROAD. IT IS YOUR RESPONSIBILITY TO CHECK FOR THIS POSSIBILITY AND TAKE AVOIDING ACTION. FAILURE TO CHECK THIS COULD RESULT IN SERIOUS INJURY.

ISSUE 1 27/09/2022 (JH)

CONSUMER NOTICE

The catalogue description and any exhibition of samples are only broad indications of the Products and R&G may make design changes which do not diminish their performance or visual appeal and supplying them in such state shall conform to the order. The Buyer acknowledges no representation or warranty (other than as to title) has been given or will apply to the Products other than those in R&G's order or confirmation and the Buyer confirms it has chosen the Products as being of merchantable quality and suitable for its particular purposes. Where R&G fits the Products or undertakes other services it shall exercise reasonable skill and care and rectify any fault free of charge unless the workmanship has been disturbed. The Buyer is responsible for ensuring that the warranty on the motorcycle is not affected by the fitting of the Products. On return of any defective Products R&G shall at its option either supply a replacement or refund the purchase money but shall not be liable if the Products have been modified or used or maintained otherwise than in accordance with R&G's or manufacturer's instructions and good engineering practice or if the defect arises from accident or neglect. Other than identified above and subject to R&G not limiting its liability for causing death and personal injury, it shall not be liable for indirect or consequential loss and otherwise its liability shall be limited to the amounts paid by the Buyer for the Products or the fitting or service concerned. These terms do not affect the Buyer's statutory rights.

R&G

Unit 1, Shelley's Lane, East Worldham, Alton, Hampshire, GU34 3AQ

Tel: +44 (0)1420 89007 Fax: +44 (0)1420 87301 www.rg-racing.com Email: info@rg-racing.com

**R&G RACING RETURNS POLICY (NON-FAULTY GOODS)**

Returns must be pre-authorized (if not pre-authorized the return will be rejected). Goods may only be returned direct to us if they were purchased direct from us (customer must prove if necessary). Otherwise to be returned to original vendor. Goods must be in re-sellable condition, in the opinion of R&G Racing. All returns are subject to a 25% restocking and handling fee (25% of the gross value exc. P&P - at the prevailing price at time of purchase). The customer must pay any and all carriage charges. No returns of discontinued products, unless within 14 days of purchase. This policy does not affect your statutory rights and does not refer to faulty goods.

R&G

Unit 1, Shelley's Lane, East Worldham, Alton, Hampshire, GU34 3AQ

Tel: +44 (0)1420 89007 Fax: +44 (0)1420 87301 www.rg-racing.com Email: info@rg-racing.com



NOTICE DE MONTAGE LP0343 SUPPORT DE PLAQUE



CE KIT CONTIENT LES ARTICLES ILLUSTRÉS ET ÉTIQUETES SUR LA PAGE.

CERTAINES PARTIES PEUVENT ÊTRE PRÉSENTES UNIQUEMENT POUR LA CLARTÉ DES INSTRUCTIONS.

NE PAS PROCÉDER AU MONTAGE TANT QUE VOUS N'ÊTES PAS SÛR QUE TOUTES LES PIÈCES SOIENT PRÉSENTES.

VEUILLEZ LIRE TOUTES LES INSTRUCTIONS AVANT DE CONTINUER.

EN CAS DE DOUTE LORS DU MONTAGE DE NOS PRODUITS, CONSULTEZ UN DE NOS REVENDEURS OU FAITES APPEL À UN TECHNICIEN QUALIFIÉ.

VEUILLEZ NOTER QUE LA FAÇON DONT LE KIT EST EMBALLÉ NE REPRÉSENTE PAS NECESSAIREMENT LA MANIÈRE DE LE MONTER SUR LA MOTO.

SI DES RONDELLES EN CAOUTCHOUC SONT UTILISÉES POUR MAINTENIR LES COMPOSANTS SUR LES BOULONS, ELLES PEUVENT ÊTRE JETÉES.

NOTICE DISPONIBLE AU TÉLÉCHARGEMENT SUR :
WWW.RG-RACING.COM

R&G

Unit 1, Shelley's Lane, East Worldham, Alton, Hampshire, GU34 3AQ
Tel: +44 (0)1420 89007 Fax: +44 (0)1420 87301 www.rg-racing.com Email: info@rg-racing.com



OUTILS REQUIS	VALEURS DE SERRAGE
<ul style="list-style-type: none"> • Clés hexagonales 3mm, 4mm et 5mm. <ul style="list-style-type: none"> • Clé Torx T30 • Clé à cliquet + douilles 6, 8 & 10mm. • Clé à molette 8mm & 10mm. <ul style="list-style-type: none"> • Tournevis cruciforme. 	M4 BOULON = 8Nm M5 BOULON = 12Nm M6 BOULON = 15Nm M8 BOULON = 20Nm M10 BOULON = 40Nm M12 BOULON = 40Nm

LÉGENDE

ARTICLE No.	DESCRIPTION	QTÉ
ARTICLE 1	TB0343 PARTIE 1 SUPPORT DE PLAQUE	1
ARTICLE 2	TB0343 PARTIE 2 SUPPORT DE PLAQUE	1
ARTICLE 3	TB0299 PARTIE 2 SUPPORT DE PLAQUE	1
ARTICLE 4	S0722 ENTRETOISE DE SUPPORT DE PLAQUE	2
ARTICLE 5	S0294 ENTRETOISE	1
ARTICLE 6	M6 x 1.00 x 20mm BOULON	2
ARTICLE 7	M6 x 1.00 x 25mm BOULON	1
ARTICLE 8	M5 x 0.8 x 15mm BOULON	8
ARTICLE 9	M6 x 12mm RONDELLE	3
ARTICLE 10	M6 x 19mm RONDELLE	2
ARTICLE 11	M5 x 10mm RONDELLE	8
ARTICLE 12	M6 ÉCROU	2
ARTICLE 13	M5 ÉCROU	8
ARTICLE 14	RB0002 BOUCHON EN CAOUTCHOUC	1
ARTICLE 15	LA0002 FEU DE PLAQUE	1
ARTICLE 16	666-896 150mm MANCHON THERMO RÉTRACTABLE	1
ARTICLE 17	CT100BK 2.5 x 100mm COLLIER DE SERRAGE	8
ARTICLE 18	CLIP 1 CLIP CÂBLE AUTOCOLLANT	4
ARTICLE 19	REFL 3 RÉFLECTEUR	1
ARTICLE 20	CON0014 CONNECTEUR DE FEU DE PLAQUE	1

R&G

Unit 1, Shelley's Lane, East Worldham, Alton, Hampshire, GU34 3AQ

Tel: +44 (0)1420 89007 Fax: +44 (0)1420 87301 www.rg-racing.com Email: info@rg-racing.com



SCHÉMA D'ENSEMBLE 1





SCHÉMA D'ENSEMBLE 2

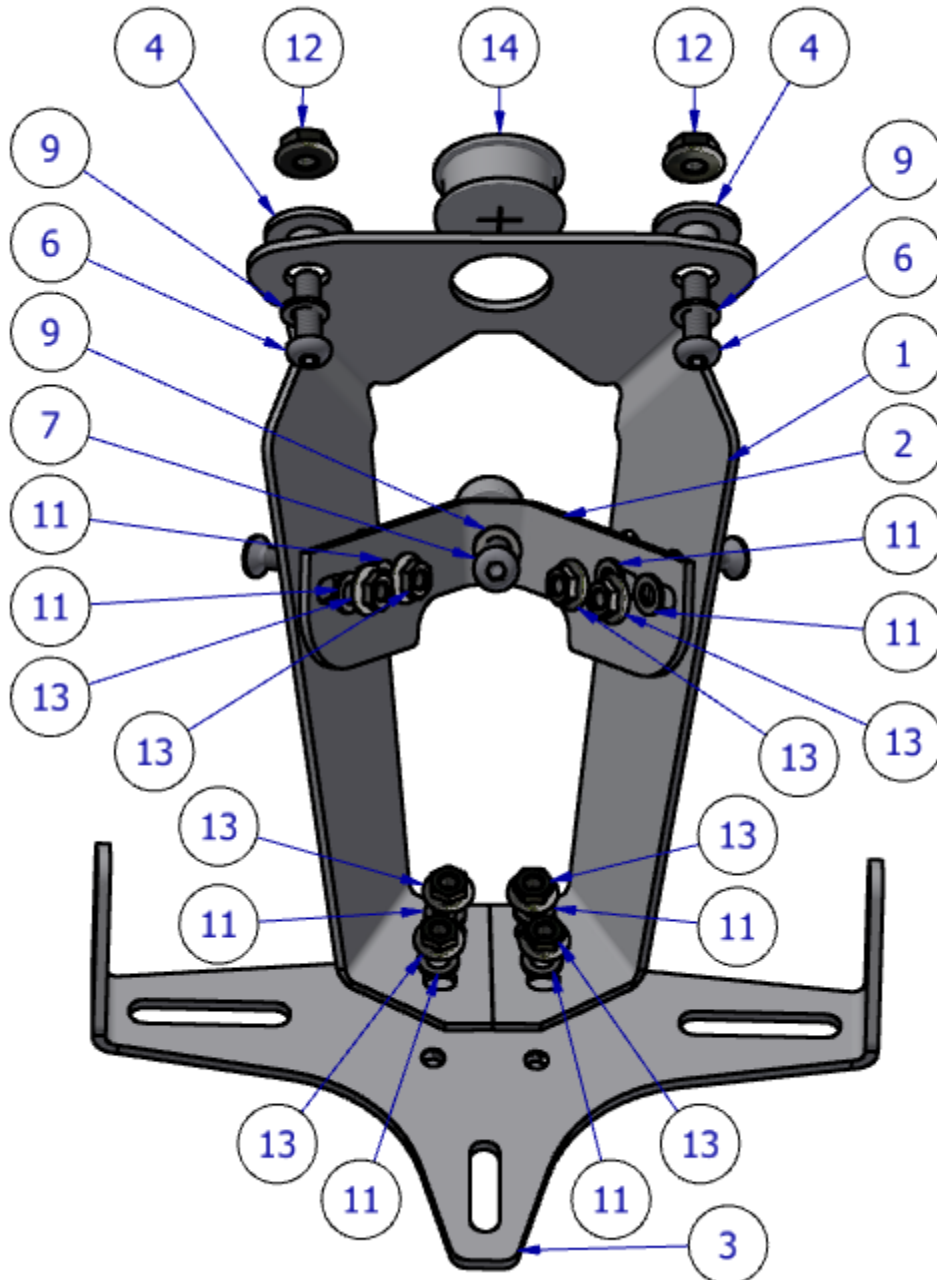
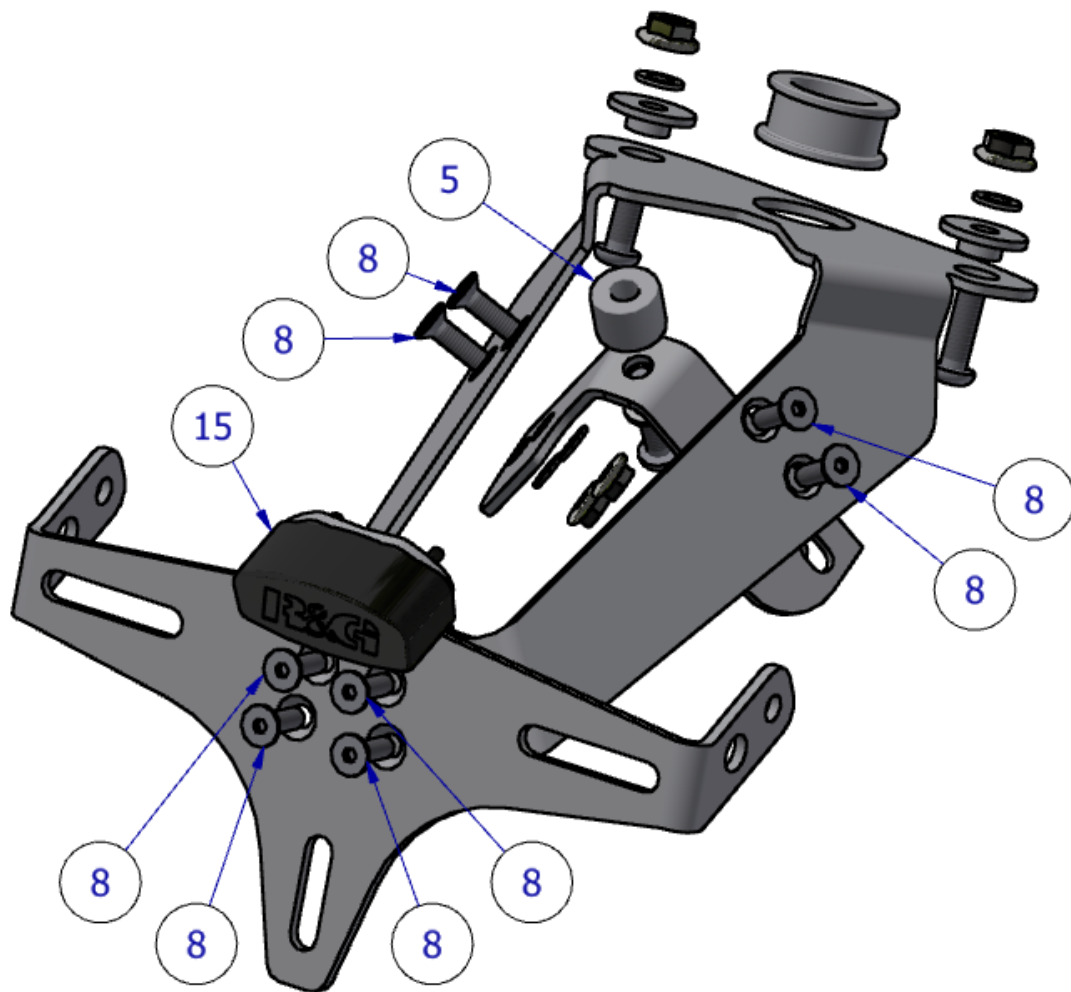

R&G

Unit 1, Shelley's Lane, East Worldham, Alton, Hampshire, GU34 3AQ

Tel: +44 (0)1420 89007 Fax: +44 (0)1420 87301 www.rg-racing.com Email: info@rg-racing.com



SCHÉMA 3

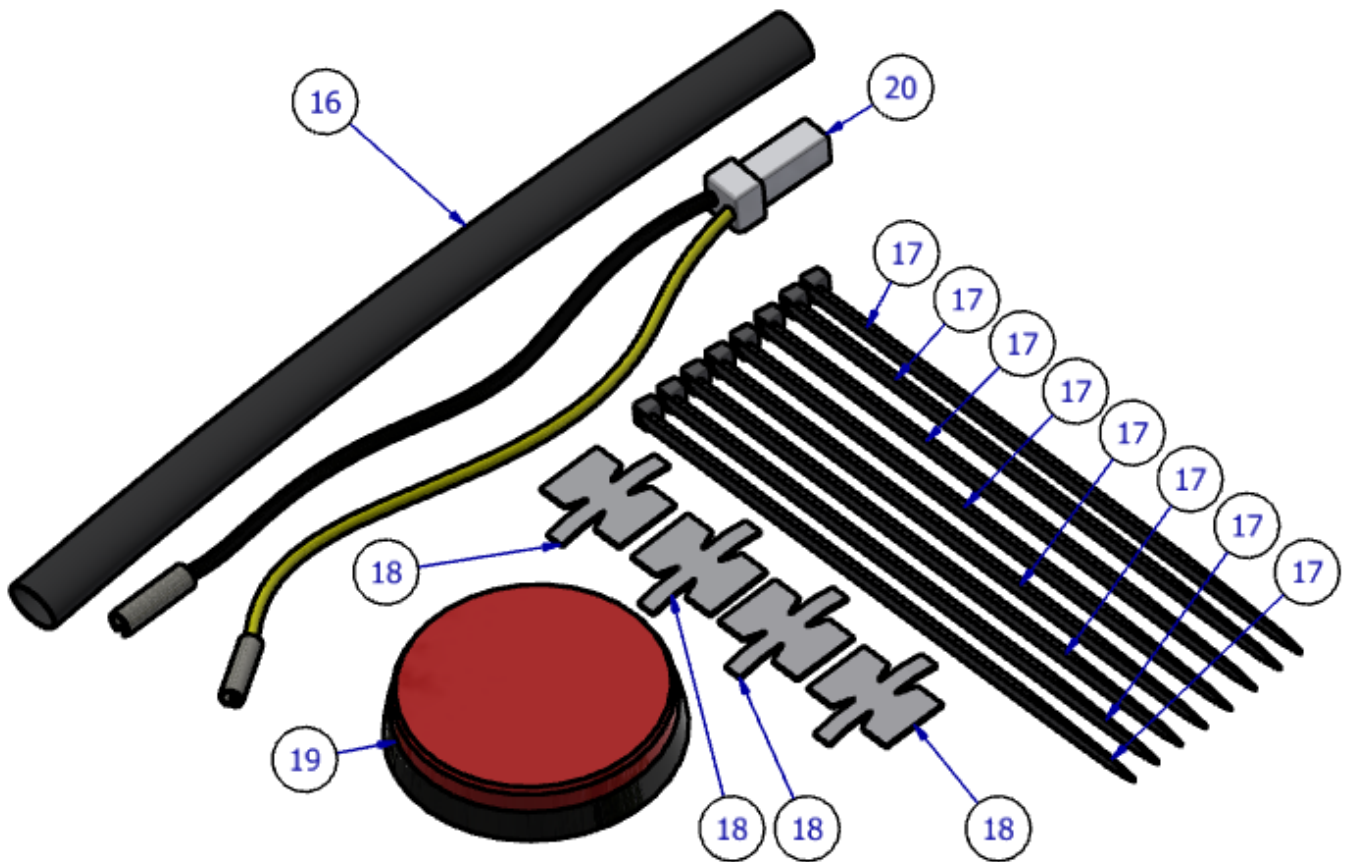



PHOTOS DE MONTAGE



PHOTO 1



PHOTO 2



PHOTO 3



NOTICE DE MONTAGE

Avant de monter le support arrière R&G, vous devrez retirer certaines pièces d'origine. Vous trouverez ci-dessous une liste suggérée de pièces à retirer.

- Siège arrière
- Panneaux latéraux arrière
- Sous la plaque de couverture du siège arrière
- Support de plaque d'immatriculation d'origine
- Mécanisme de verrouillage du siège
- Clignotants d'origine
- Débranchez les fils des clignotants et des feux de plaque d'immatriculation

Assemblage du support

Avant d'assembler ce produit, assurez-vous que tous les composants de la boîte soient corrects en comparant la légende et les schémas.

- 16.** Pour commencer à assembler le support arrière, connectez (ARTICLE 1) et (ARTICLE 2) à l'aide de x4 (ARTICLE 8) (ARTICLE 11) (ARTICLE 13) comme indiqué dans le SCHÉMA 1-2. NE PAS SERRER COMPLÈTEMENT À CE STADE.

Connectez (ARTICLE 3) à l'ensemble qui a présent est assemblé (ARTICLE 1/2) en utilisant x4 (ARTICLE 8) (ARTICLE 11) (ARTICLE 13) comme indiqué sur le SCHÉMA 1-2.

17. Une fois que (ARTICLE 3) est connecté, vous pouvez fixer (ARTICLE 15) dans les trous de montage sur (ARTICLE 3) comme indiqué sur le SCHÉMA 2. ASSUREZ-VOUS QUE LES FILS SOIENT PASSÉS À TRAVERS (ARTICLE 3). Une fois serré, glissez la THERMORÉTRACTABLE (ARTICLE 16) sur les fils de (ARTICLE 15).
18. Comme indiqué sur le SCHÉMA 1, poussez (ARTICLE 14) dans le trou de (ARTICLE 1).
19. Pour faciliter le rangement des câbles, vous devrez utiliser le CLIP DE CÂBLE AUTO-ADHÉSIF (ARTICLE 18) pour fixer les câbles à l'intérieur de (ARTICLE 1) de chaque côté.
20. Pousser les câbles à travers le trou (ARTICLE 14).
21. Pour installer les ENTRETOISES DE MONTAGE DU SUPPORT (ARTICLE 4), vous devrez remplacer directement les ENTRETOISES d'origine comme indiqué sur la PHOTO 1.
22. Maintenant que le support est assemblé, il est temps de le fixer à la moto. Pour ce faire, placez l'ensemble dans le même emplacement de montage que le support de plaque d'immatriculation d'origine en utilisant x2 (ARTICLE 6) (ARTICLE 9) (ARTICLE 12).

ASSUREZ-VOUS DE FAIRE-

Assurez-vous que la rondelle (ARTICLE 9) soit placée sur le boulon (ARTICLE 6) avant de le monter. Faites également passer les fils à travers le petit trou du passage de roue arrière comme indiqué sur la PHOTO 2.

Une fois le support monté sur la moto, assurez-vous qu'il soit bien serré et sécurisé.

R&G

Unit 1, Shelley's Lane, East Worldham, Alton, Hampshire, GU34 3AQ

Tel: +44 (0)1420 89007 Fax: +44 (0)1420 87301 www.rg-racing.com Email: info@rg-racing.com



1. Après avoir monté le support arrière, le boulon central (ARTICLE 7) avec rondelle (ARTICLE 9) devra être boulonné à travers le trou de montage du SUPPORT DE PLAQUE D'IMMATRICULATION (ARTICLE 2) comme indiqué sur le SCHEMA 1-2.

Assurez-vous que l'ENTRETOISE (ARTICLE 5) soit placée entre l'emplacement de montage de la moto et (ARTICLE 2).

2. Branchez les fils de feu de la plaque d'immatriculation (ARTICLE 15) dans le connecteur de feu de la plaque d'immatriculation (ARTICLE 20) comme indiqué sur la PHOTO 3. Une fois connecté, branchez (ARTICLE 20) dans le connecteur de l'éclairage de la plaque d'immatriculation d'origine de la moto.
3. Serrez maintenant à fond (ARTICLE 1) et (ARTICLE 2).
4. Assurez-vous que tous les écrous et boulons aient été correctement serrés en utilisant le tableau des RÉGLAGES GÉNÉRAUX DE COUPLE à la PAGE 2.
5. Allumez la moto pour vérifier que le feu de la plaque d'immatriculation (ARTICLE 15) fonctionne.
6. Pour installer les clignotants d'origine, retirez-les de l'unité arrière d'origine en retirant l'écrou de fixation de chaque clignotant et enfitez le fil à travers le support pour le retirer.

En vous assurant de fixer les clignotants du bon côté, enfitez le connecteur et le fil à travers le support de clignotant sur le support de plaque d'immatriculation et le trou de fil (ARTICLE 1). Ensuite, serrez fermement les clignotants avec l'écrou de clignotant d'origine.

7. Dernière étape, réinstallez toutes les pièces d'origine à l'exception du support de plaque d'immatriculation d'origine.

IMPORTANT : SI VOUS MONTEZ UNE PLAQUE D'IMMATRICULATION LARGE ET QUE VOUS LA PLACEZ ASSEZ BASSE SUR LE SUPPORT DE PLAQUE D'IMMATRICULATION, IL EST POSSIBLE QUE LA PLAQUE D'IMMATRICULATION TOUCHE LA ROUE ARRIÈRE SOUS UNE CHARGE LOURDE ET SUR DE GROSSES BOSSES SUR LA ROUTE. IL EST DE VOTRE RESPONSABILITÉ DE VÉRIFIER CETTE POSSIBILITÉ ET DE PRENDRE DES MESURES POUR ÉVITER. NE PAS VÉRIFIER CELA POURRAIT ENTRAÎNER DES BLESSURES GRAVES.

ISSUE 1 27/09/2022 (JH)

CONSUMER NOTICE

The catalogue description and any exhibition of samples are only broad indications of the Products and R&G may make design changes which do not diminish their performance or visual appeal and supplying them in such state shall conform to the order. The Buyer acknowledges no representation or warranty (other than as to title) has been given or will apply to the Products other than those in R&G's order or confirmation and the Buyer confirms it has chosen the Products as being of merchantable quality and suitable for its particular purposes. Where R&G fits the Products or undertakes other services it shall exercise reasonable skill and care and rectify any fault free of charge unless the workmanship has been disturbed. The Buyer is responsible for ensuring that the warranty on the motorcycle is not affected by the fitting of the Products. On return of any defective Products R&G shall at its option either supply a replacement or refund the purchase money but shall not be liable if the Products have been modified or used or maintained otherwise than in accordance with R&G's or manufacturer's instructions and good engineering practice or if the defect arises from accident or neglect. Other than identified above and subject to R&G not limiting its liability for causing death and personal injury, it shall not be liable for indirect or consequential loss and otherwise its liability shall be limited to the amounts paid by the Buyer for the Products or the fitting or service concerned. These terms do not affect the Buyer's statutory rights.

R&G

Unit 1, Shelley's Lane, East Worldham, Alton, Hampshire, GU34 3AQ

Tel: +44 (0)1420 89007 Fax: +44 (0)1420 87301 www.rg-racing.com Email: info@rg-racing.com

**R&G RACING RETURNS POLICY (NON-FAULTY GOODS)**

Returns must be pre-authorised (if not pre-authorised the return will be rejected). Goods may only be returned direct to us if they were purchased direct from us (customer must prove if necessary). Otherwise to be returned to original vendor. Goods must be in re-sellable condition, in the opinion of R&G Racing. All returns are subject to a 25% restocking and handling fee (25% of the gross value exc. P&P – at the prevailing price at time of purchase). The customer must pay any and all carriage charges. No returns of discontinued products, unless within 14 days of purchase. This policy does not affect your statutory rights and does not refer to faulty goods.

R&G

Unit 1, Shelley's Lane, East Worldham, Alton, Hampshire, GU34 3AQ

Tel: +44 (0)1420 89007 Fax: +44 (0)1420 87301 www.rg-racing.com Email: info@rg-racing.com